

QTTM

SOUND INSULATION

Tested. Proven. Guaranteed.



TECHNICAL MANUAL

INSTALLATION • WARRANTY

1•866•326•5712 • www.QTsoundcontrol.com

Table of Contents

Base Preparation

I. General Information	3
II. Job Site Conditions	3
III. Subfloor Requirements & Preparation	3-4
IV. Hazards	4
V. Material Storage and Handling	5

Installation

I. Perimeter Isolation Strips	5-6
II. QTrbm	6-7
III. QTscu	7-9
IV. Alternative Installation Methods	9-10
V. Floor Finish	10-11
VI. Baseboard	11
VII. Recommended Materials	11-12

Warranty

Warranty Information	13
----------------------	----

©2009 ECORE International™ All Rights Reserved.

This document may not be altered in any form or by any means.

No warranty of accuracy is given concerning the contents of the information contained in this publication. To the extent permitted by law, no liability (including liability to any person by reason of negligence) will be accepted by ECORE, its subsidiaries or employees for any direct or indirect loss or damage caused by omissions or inaccuracies in this document. ECORE reserves the right to change details in this publication without notice.

Base Preparation

I GENERAL INFORMATION

The QT line of products for impact sound insulation is engineered to provide better performance than any other sound control product available, and has been rigorously tested to achieve proven results. Made from 92% resilient recycled rubber and backed by over 200 independent laboratory and field tests, QT has been selected and used in some of the best hotels and condominiums in the world. It can be installed under most types of grouted, glued, and floating floors including ceramic tile, stone, marble, brick, pavers, hardwood, engineered wood, laminate, parquet, vinyl, and carpet.

II JOB SITE CONDITIONS

Areas to receive QT should be weather tight and maintained at minimum, a constant room temperature of 65°F (10°C) for 48 hours before, during, and after installation.

III SUBFLOOR REQUIREMENTS & PREPARATION

A. GENERAL

NOTE: Please follow the subfloor requirements and preparation recommendations determined by the flooring manufacturer. Use the following subfloor requirements and preparation guidelines only when no such recommendations exist for the floor finishing product.

1. All subfloors/substrates must be inspected prior to installation.
2. Install QT over concrete, approved self-leveling materials, and wood.
3. Wood subfloors should be double construction with a minimum thickness of one inch. The floor must be rigid and free from movement with a minimum of 18 inches of well-ventilated air space below.
4. Wood subfloors (when installed with use of grouted floor coverings like tile) must be prepared according to ANSI L/360 standards, as required by the floor covering manufacturer.

NOTE: Particleboard, often called “chipboard,” masonite, and lauan are not suitable underlayments.

5. Concrete floors must be fully cured and permanently dry. Subfloor shall be dry, clean, smooth, level, and structurally sound. It should be free of dust, solvent, paint, wax, oil, grease, asphalt, sealers, curing and hardening compounds, alkaline salts, old adhesive residue, and other extraneous materials, according to ASTM F710.
6. Subfloor should be smooth to prevent irregularities, roughness, or other defects from telegraphing through the material. The surface should be flat to the equivalent of 3/16” (3.9mm) in 10’, as described in ACI 117R, or as recommended by the flooring manufacturer.

7. Mechanically remove all traces of old adhesives, paint, or other debris by scraping, sanding, or scarifying the substrate. DO NOT use solvents.
8. Grind all high spots until level and fill low spots with an approved patching/leveling compound.
9. All saw cuts (control joints), cracks, indentations, and other non-moving joints in the concrete must be filled with an approved patching/leveling compound. Allow patching material to dry thoroughly.
10. Any concrete subfloor can be a source of moisture-related flooring failures. It is the installer's responsibility to test the concrete or other cement-like material for moisture.
11. Maximum moisture vapor emission of the concrete must not exceed 5 ½ lbs/1,000 sq ft in a 24 hour period, as measured by the calcium chloride test method in accordance with the ASTM F1869 standard. If vapor emissions exceed acceptable limits, the installation should not proceed until the problem has been corrected.
12. Moisture can also be measured using the RH, Relative Humidity test method per the ASTM F2170 standard. Moisture content should not exceed 75% RH. If levels are higher using either test method an ECORE recommended vapor retardant must be utilized.

IV HAZARDS

A. SILICA WARNING

1. Concrete, floor patching compounds, toppings, and leveling compounds can contain free crystalline silica. Cutting, sawing, grinding, or drilling can produce respirable crystalline silica (particles 1-10 micrometers). Respirable silica is classified by OSHA as an IA carcinogen and is known to cause silicosis and other respiratory diseases. Avoid actions that cause dust to become airborne. Use local or general ventilation or protective equipment to reduce exposure below applicable exposure limits.

B. LEAD WARNING

1. Certain paints may contain lead. Exposure to excessive amounts of lead dust presents a health hazard. Refer to applicable federal, state, and local laws and the publication, *Lead Based Paint: Guidelines for Hazard Identification and Abatement in Public and Indian Housing*, available from the United States Department of Housing and Urban Development.

C. ASBESTOS WARNING

1. Resilient flooring, backing, lining felt, paint, or asphaltic "cutback" adhesives could contain asbestos fibers. Avoid actions that cause dust to become airborne. DO NOT sand, dry sweep, dry scrape, drill, saw, beadblast, mechanically chip, or pulverize.

Regulations may require that the material be tested to determine asbestos content. Consult the documents titled, *Recommended Work Practices for Removal of Existing Resilient Floor Coverings*, available from the Resilient Floor Covering Institute.

V MATERIAL STORAGE AND HANDLING

A. GENERAL

1. Deliver the material to the job site in its original unopened packaging with all labels intact and stored appropriately to prevent damage.
2. Inspect all material for visual defects before beginning the installation. ECORE will honor no labor claim on material installed with any visually apparent defects.
3. Verify the material delivered is the correct type, thickness, and amount. Report any discrepancies immediately.
4. The material and any adhesive must be acclimated at room temperature for a minimum of 24 hours before starting the installation.
5. Roll material is stretched slightly when it is rolled at the factory. At the job site, the installer should allow all cuts to relax before gluing down. Shaking the material once it is unrolled can help it to relax more quickly.

Installation

I PERIMETER ISOLATION STRIPS

A. GENERAL

NOTE: It is essential to install the QT Perimeter Isolation Strip before placing and trimming QT Impact Sound Insulation Material!

1. Attach the QT Perimeter Isolation Strip to the perimeter wall of the entire subfloor, as well as around the perimeter of any protrusions, in order to isolate or break the vibration transmission path between the floor and the wall (see diagram #1).

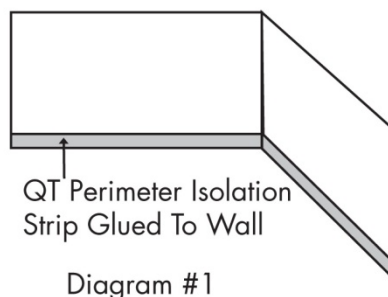

2. Temporarily fasten the QT Perimeter Isolation Strip in place with masking tape, duct tape, carpet tape or spot gluing. The Perimeter Isolation Strip will later be trimmed flush with the new top layer of flooring above QT layer.

II QTrbm

QT resilient base mat (rbm) is a dimpled, resilient base mat for installation under gypsum or full weight concrete to produce some of the thinnest sound rated systems in the industry. Available in 48" and 54" wide rolls and four standard thicknesses – 6mm, 10mm, 17mm, and 25mm. QTrbm is available with a waterproof membrane (identified by a "W" suffix).

A. INSTALLING QTrbm

1. Attach the Perimeter Isolation Strip to the wall (see diagram #1).
2. Assume the walls you are butting up against are not square. Using a chalk line, create a starting point for an edge of the material to follow.
3. If you have not already done so, remove the shrink-wrap from the roll of QTrbm and unroll it onto the floor. Shaking the material once it is unrolled can help it to relax.
4. Always lay the QTrbm so that the dimples are down against the subfloor. Some variations of QTrbm are available with a waterproof membrane laminated to the top surface. Install the QT so that this membrane surface is on top.
5. Trim the ends of each section as necessary in order to fit the surface area to be covered. Maintain the required ambient conditions for any adhesive application and bonding.
6. Align the lengthwise edge of the material exactly with that of the neighboring section. Edges must contact but not overlap.
7. Dry lay the rolls onto the subfloor. Use high quality 3" wide duct tape to secure all joints and seams.

B. INSTALLATION OF GYPSUM TOPPING

1. Install gypsum flooring underlayment product to a minimum thickness of 1". Install the gypsum layer according to the recommendations of the gypsum manufacturer. Thickness of the gypsum layer may depend on thickness of the QTrbm layer.
2. Properly heat and ventilate the building interior before, during, and after the installation of the gypsum product constant room temperature of 50°F (min.) and controlled humidity of 50% (max.). Under these conditions, a 1" thick gypsum floor underlayment should be dry in about seven to ten days.
3. Open windows daily a minimum of 2" to allow for the evaporation of moisture.

NOTE: A building without all of these conditions present will significantly increase the drying time of the gypsum product.

4. Before applying the sealer or installing the finished floor goods, be sure that the gypsum underlayment is sufficiently dry by testing it using the plastic sheet method per ASTM D4263 or a method recommended by the gypsum manufacturer.
5. Install the finished floor in accordance with the flooring manufacturer's directions. After installing the finished floor, trim the excess Perimeter Isolation Strip around the entire perimeter of the finished floor (see diagram #2). You may consult with the floor covering installer to see if they would like the Perimeter Isolation Strip to remain in place.

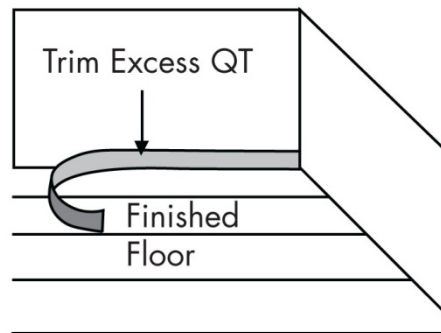

Diagram #2

III QTscu

QT sound control underlayment (scu) is a flat, resilient underlayment that is used directly under a variety of floor finishes, including ceramic tile, vinyl, wood, laminate, and stone, yielding exceptional results over both concrete and wood joist constructions. QTscu is available in 48" wide rolls, and in five standard thicknesses – 5mm to 10mm. Other custom thicknesses are available upon request. QTscu is available with a waterproof membrane (identified by a "W" suffix) or with a peel and stick option (identified by a "P" suffix).

A. INSTALLING QTscu

1. Attach the Perimeter Isolation Strip to the wall (see diagram #1).
2. Assume the walls you are butting up against are not square. Using a chalk line, create a starting point for an edge of the material to follow.
3. If you have not already done so, remove the shrink-wrap from the roll of QT and unroll it onto the floor. Shaking the material once it is unrolled can help it to relax.
4. Place the QTscu material so that it is perpendicular to the subsequent installation direction of the topping material (see diagram #3).

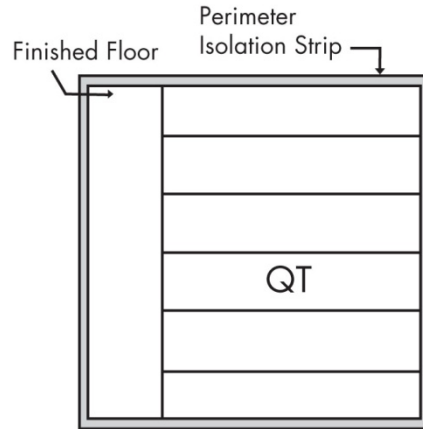

Diagram #3

5. Trim the ends of each section as necessary in order to fit the surface area to be covered. You may trim section ends to exact dimensions required (e.g. joints with walls, etc.).
6. Align the lengthwise edge of the material exactly with that of the neighboring section. Edges must contact but not overlap.

B. GLUING QTscu

NOTE: When using grouted or fully adhered flooring materials, the QTscu shall be fully adhered to the substrate with a suitable adhesive. No substitutions are permitted.

1. Fold the first drop lengthwise (half the width of the roll). Spread adhesive using proper notch trowel.

NOTE: Temperature and humidity affect the open time of adhesive. The installer should monitor on-site conditions and adjust open time accordingly.

2. Carefully lay the material into the wet adhesive. DO NOT let the material fall because this will trap air beneath the material.
3. Fold over second half of first sheet and first half of second sheet (see diagram #4).

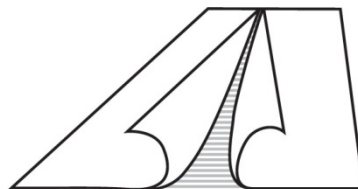

Diagram #4

4. Spread the adhesive. At seam area, spread adhesive at 90 degrees to seam to prevent excessive adhesive oozing up to the surface of the material.

5. Continue the process for each consecutive drop. Always work at a pace so that you are always folding material back into wet adhesive.
6. Never leave adhesive ridges or puddles, as they may telegraph through the material.
7. Use a 30 to 50 lb roller to roll over the floor within 45 minutes to ensure proper transfer of adhesive. Overlap each pass of the roller by 50% of the previous pass to ensure that the floor is properly rolled.

IV ALTERNATIVE INSTALLATION METHODS

A. PEEL AND STICK FOR QT_{scu}

1. Newly poured concrete surfaces must be completely clean and dry. Check with concrete manufacturer for specified cure time.
2. Specco S-55 sealer must be installed over concrete surface.
3. Stir the contents of the container before using. Dilute Specco S-55 one part to four parts potable water (by volume) and mix thoroughly.
4. Use a roller, brush, or spray to apply S-55. Avoid puddles and runs. Coverage rates will vary with the absorption rate of the surface.
5. Approximate coverage rate is 200 to 300 square feet per gallon. Drying time at 77° F is approximately one hour. Clean tools with soap and water immediately following use.
6. Unroll QT_{scu} while the release sheet is still attached. Position it over the area to be treated and cut to appropriate length.
7. Roll up half of the QT_{scu}, leaving the other half still in position. Peel the release sheet from the rolled up portion and pull it towards you, exposing and unrolling the self-stick portion of the QT_{scu}.
8. Re-roll the unrolled portion of the QT_{scu} and follow the same procedure.
9. Check the positioning and smooth out wrinkles and bubbles with a flat trowel and roll with a 30 to 50 lb. (13-26 kg) roller to ensure complete contact with the substrate.
10. Slice air pockets and wrinkles and smooth with a roller or the flat side of a trowel. Align subsequent sheets and butt join the seams tightly but do not overlap them.

B. USING TAPE (FOR FLOATING FLOOR COVERING INSTALLATIONS)

1. Dry lay the rolls onto the subfloor following the directions on page 7.
2. Use duct tape or a high-quality carpet tape to secure the butt joints and seams.

3. A high quality 3" wide duct tape can be used to prevent the QTscu from moving on the substrate.

NOTE: Gluing down of the QTscu is not required for floating floors.

C. USING BOTH QTrbm AND QTscu IN THE SAME ASSEMBLY.

1. The most common method for this type of installation begins by installing QTrbm.
2. Install the dimpled material in accordance with the instructions provided in the section "Installing QTrbm" beginning on page 3 of this manual.
3. Have the gypsum or other underlayment material installed per the manufacturer's recommendations.
4. Once cured or hardened to the gypsum manufacturer's specifications, start the installation of the QTscu with the instructions provided in the section "Installing QTscu" beginning on page 7 of this manual.

V FLOOR FINISH

A. GENERAL

1. Follow the flooring manufacturer's directions for installing the flooring. Use their recommended adhesives, procedures, and equipment. When installing vinyl or linoleum flooring products directly on QTscu, a layer of ECORE's E-Grip™ III adhesive shall be back-troweled onto its surface. This process seals the QT to prevent chemical migration. It also provides a monolithic layer onto which the flooring manufacturer's recommended adhesive can be spread.
2. **Do not** mechanically fasten any material through QT. Any mechanical connection, such as nails, screws, staples, etc., will transmit noise through to the building structure, compromising the performance of QT.

B. INSTALLATION

1. Install self-locking floors, such as wood laminates, over QTscu following the manufacturer's recommendations.
2. Glue standard wood flooring directly to QT using the flooring manufacturer's recommended adhesive.
3. If a flooring manufacturer recommends the installation of a layer of plywood or cement board between the QT and the finished flooring, glue the recommended board using a suitable adhesive.
4. Install grouted flooring materials in a thin or thick-set mortar bed applied directly on the QTscu.

5. When the flooring installation is complete, trim any excess QT material so that it is flush with the surface of the finished floor.

VI BASEBOARD

A. INSTALLATION OF BASEBOARD

1. After perimeter installation strip has been trimmed to finished floor height install the baseboard.
2. Fix the baseboard to the wall above the QT. The baseboard must not touch the finished floor (see diagram #5).
3. Seal the entire perimeter with a permanently flexible acoustical caulk.

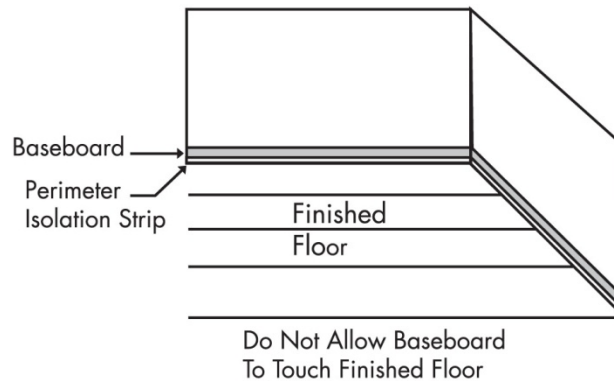

Diagram #5

VII RECOMMENDED MATERIALS

NOTE: All materials shall be delivered to the job site in the original containers with the manufacturer's identification on each package. Unauthorized modification to any product is not permitted. The following materials are listed because of their extensive testing and field experience with QT products. If you would like us to evaluate any materials as alternatives, please call ECORE Technical Services at (800) 322-1923.

A. URETHANE ADHESIVES

1. E-Grip III by ECORE International (800) 322-1923
2. Bostik's Best® by Bostik® (800) 592-8858
3. DriTac 7500/7600 by DriTac (800) 394-9310
4. Henry #971 (800) 232-4832

B. THIN-SET MATERIALS

1. ARDEX FB9L (724) 203-5000
2. ARDEX X701
3. ARDEX X7G Plus
4. ARDEX S16
5. Bostik[®] Hydroment[®] Single-Flex™ Mortar
6. Laticrete[®] 253 Gold
7. Laticrete[®] 254 Platinum
8. Laticrete[®] Sure Set

C. GROUT MATERIALS

1. ARDEX Flex Grout
2. Bostik[®] Hydroment[®] Joint Filler
3. Laticrete[®] PermaColor™ Grout
4. Laticrete[®] SpectraLOCK[®] Grout

WARRANTY INFORMATION

The recommendations for applications and installation are based on our extensive experience and on current technological practice. Our liability and responsibility in the event of damages is limited to the extent defined in our General Terms and Conditions of Business and is not in any way increased by the above recommendations or by advice given by our sales representatives or applications engineering staff. ECORE is a corporation duly organized and validly existing under the laws of the Commonwealth of Pennsylvania.

ECORE offers a limited lifetime warranty on the QT brand of Impact Sound Insulation products against defects in material and workmanship and QT shall meet all published specifications and shall perform effectively. ECORE warrants that during the warranty period QT shall not harden, become brittle, chip, crack, tear, or exhibit any signs of excessive deterioration except for normal wear and tear. All other warranties, including implied warranties for a particular purpose, are expressly excluded. The sole remedy against the seller will be the replacement or repair of the defective goods, or at seller's option, credit may be issued not exceeding the selling price of the defective good.

For more information and samples call 1-866-326-5712 or visit www.QTsoundcontrol.com

@2009 All designs and colors are copyrighted by ECORE Intl. QT is a registered trademark of ECORE Intl. QTscu and QTrbm patents pending. E-Grip is a trademark of ECORE Intl. Bostik, Hydroment, and Bostik's Best are registered trademarks of Bostik. Single-Flex is a trademark of Bostik. Custom Building Products, MasterBlend, PolyBlend, VerseBond, and FlexBond are registered trademarks of Custom Building Products. CustomFlex is a trademark of Custom Building Products. TEC and Super Flex are trademarks of Specialty Construction Brands. Full Flex, 1 Flex, and Accucolor are registered trademarks of Specialty Construction Brands.

QT4016-0810