



LVT and Plank over 2mm & 5mm QT Technical Manual

SPECIAL PROCEDURES INSTALLATION & WARRANTY

Manufactured in the U.S.A. by:



Revised 9/15/2020
Supersedes all previous versions
Check website for updates

TABLE OF CONTENTS



INSTALLATION

Job Site Conditions	3
Substrate Preparation	3
Perimeter Isolation Strip	4
Installation of QT Sound Mat	5
Adhesive & Trowel Recommendations	5
Adhesive and LVT/LVP Installation	5
Adhesive LVT/LVP over QT	7
Adhesive LV/LVP over Substrate	8
Adhesive Data and Coverage	9

WARRANTY

Warranty	10
----------	----

2mm and 5mm QT Adhesive Coverage Rate Calculator

QT	Trowel Size		Coverage Rate Over Standard Substrates	Coverage Rate Over Sound Mats
2mm QT	 1/32" x 1/16" x 1/32" (1 x 1.5 x 1 mm)	Use to secure 2mm QT to substrate and LVT/LVP to 2mm QT	150 to 200 sq. ft./gal	150 sq. ft./gal
5mm QT	 1/16" x 1/16" x 1/16" (1.5 x 1.5 x 1.5 mm)	Use to secure 5mm QT to substrate and LVT/LVP to 5mm QT	100 to 125 sq. ft./gal	100 sq. ft./gal

Coverage rates shown here are for estimating purposes only. Actual jobsite coverage may vary according by application method, substrate, substrate conditions, trowel angle, and actual thickness applied.

SUBSTRATE PREPARATION

IMPORTANT: Areas to receive flooring must be weather tight and maintained at a minimum uniform temperature of 65° F (18° C) for 48 hours prior to, during, and after installation. Failure to comply could result in flooring failure.

Step 1: Concrete substrate shall be prepared according to ASTM F710 standards. This standard calls for complete removal of all extraneous materials that may affect the adhesive bond. These materials include, but are not limited to, dust, paint, wax, solvents, adhesive residue, curing & hardening compounds, and sealers. If any of these are present, they must be removed prior to installation of flooring materials. Keep in mind that they should be removed mechanically without the use of chemicals, which could also act as a bond breaker for the adhesive.

The concrete should be given a sufficient amount of time to dry, naturally, before the application of adhesives. The moisture content should always be tested using the ASTM F-2170 testing for relative humidity. Relative humidity should result in a level of 80% or lower with diminishing results. If levels exceed these parameters, then the installation should not proceed until the situation has been corrected.

In the event that a moisture mitigation system is required, it must conform to the ASTM F3010 Standard Practice for Two-Component Resin Based Membrane Forming Moisture Mitigation Systems for use Under Resilient Floor Coverings.

NOTE: When using approved Mapei patching materials, Mapei's Primer T must be used over the surface of the patch before applying adhesive in Step 2 below. Failure to use primer may result in cohesive failure of the patching materials. Primer dilution shall be 2 parts water: 1 part primer.

Step 1: Gypsum substrates shall be prepared according to the ASTM F 2419 standards. This standard covers the practice of installation and preparation of the thick poured gypsum concrete underlayments over wood structural panel subfloors in commercial structures, or over concrete floors in commercial structures and preparation of the surface prior to the installation of resilient flooring.

NOTE: Per the ASTM C472 standard, the gypsum substrate shall have a compressive strength of 3000 psi or greater, and a density of 105 pcf.

Before installation of resilient flooring, gypsum must be primed with Mapei's Primer T at a dilution rate of 2 parts water: 1 part primer.

It is crucial that primer is allowed to penetrate deep into the pores of the gypsum. It may be necessary to apply multiple coats.

SUBSTRATE PREP & PERIMETER ISOLATION STRIP

Drying time of gypsum shall be determined using the ASTM F2419 standards, which reference the ASTM C472 and ASTM D4263 standards for moisture content.

It is important for the gypsum substrate to be free of imperfections and that it be level to the equivalent of 3/16" in 10'. If substrate is damaged, it must be flash patched before installation of the resilient floor covering.

Flash patching can be completed using one of Mapei's approved patches or self-leveling materials. Please contact Mapei Technical Support for assistance.

Step 1: Wood subfloors should be double construction, rigid, and free from movement.

Wood subfloors (when installed with grouted floor coverings like tile) must be prepared according to ANSI L/360 standards, as required by the floor covering manufacturer.

NOTE: Particleboard, often called "chipboard," masonite, and luan are not suitable underlayments.

Step 2: Day 1: It is essential to install the QT Perimeter Isolation Strip before placing and trimming QT impact sound insulation material!

Attach the QT Perimeter Isolation Strip to the perimeter wall of the entire subfloor, as well as around the perimeter of any protrusions, in order to isolate or break the vibration transmission path between the floor and the wall (see diagram #1).

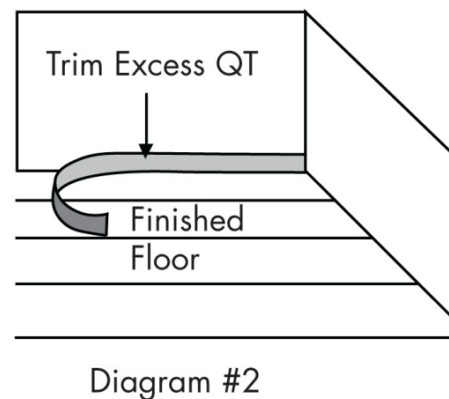
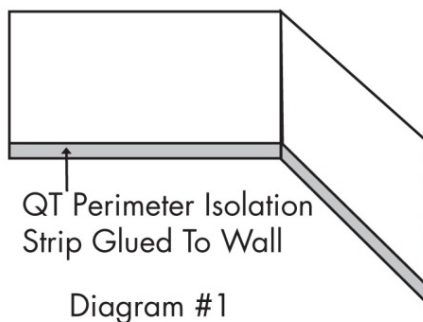

Temporarily fasten the QT Perimeter Isolation Strip in place with masking tape, duct tape, carpet tape or spot gluing. The Perimeter Isolation Strip will later be trimmed flush with the finished floor. (Diagram #2)

INSTALLATION

Assume the walls you are butting up against are not square. Using a chalk line, create a starting point for an edge of the material to follow.

If you have not already done so, remove the shrink-wrap from the roll of QT and unroll it onto the floor. Shaking the material once it is unrolled can help it to relax.

Place the QTscu material so that it is perpendicular to the subsequent installation direction of the topping material (see diagram #3).

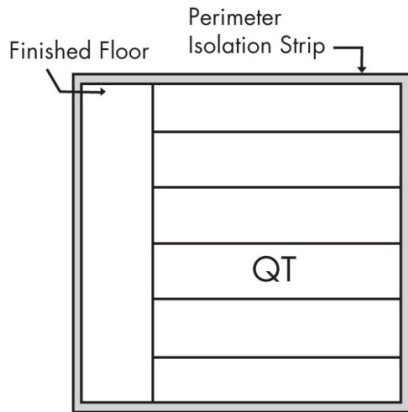

Diagram #3

QT sound mat shall be adhered to the substrate using the approved trowel.

2MM sound mat – 1/32” x 1/16” x 1/32” trowel using the required E-Grip Evolve.

5MM sound mat – 1/16” square notch trowel using the required E-Grip Evolve.

After laying sound mat into adhesive bed, it shall be rolled with a three section flooring roller. For **2MM** QT use a 35 lb roller. For **5mm** QT use a 75-100 lb roller. Allow adhesive to cure for 24 hours before proceeding with **Step 3**.

Step 3: Day 2: Apply LVT/LVP over QT sound mat using the approved trowel size listed below.

- **2MM sound mat – 1/32” x 1/16” x 1/32” trowel** using the required E-Grip Evolve adhesive. Coverage rate approximately 150 sq ft/gal.
- **5MM sound mat – 1/16” square notch trowel** using the required E-Grip Evolve adhesive. Coverage rate approximately 100 sq ft/gal.

Very Important to follow adhesive application instructions to ensure a successful installation. Ecore cannot be held liable for improper installation techniques.

INSTALLATION

Areas to receive flooring must be weather tight and maintained at a minimum uniform temperature of 65° F (18° C) for 48 hours prior to, during, and after installation. Failure to comply could result in flooring failure.

(Step 3: Day 2 Continued – Application of adhesive and Installing Tile and Plank)

NOTE: Adhesive coverages listed are for estimating purposes only. Actual jobsite coverage may vary.

1. Apply adhesive to surface of QT sound mat using appropriate trowel listed below. Trowel size varies with sound mat thickness.
 - **2MM sound mat** – Apply LVT/LVP using a **1/32” x 1/16” x 1/32” trowel** using the required E-Grip Evolve adhesive. Coverage rate approximately 150 sq ft/gal.
 - **5MM sound mat** – Apply LVT/LVP using a **1/16” square notch trowel** using the required E-Grip Evolve adhesive. (Coverage rate approx. 100 sq ft/gal.)
2. Work only in small sections to install into adhesive bed within the specified ***working time**.
3. Allow adhesive to ****flash** until adhesive valley is clear and adhesive ridge is gummy to the touch, approximately 30-45 minutes over 2mm QT, and approximately 90-120 minutes over 5mm QT. (See page 7)
4. Carefully lay planks into the adhesive bed. Work off of the planks to eliminate excess movement before adhesive cures.
5. After completing each section within arm’s reach, roll the planks with the specified 100 lb. three section flooring roller.
6. Prohibit foot traffic for a minimum of 48 hours after installation and light rolling loads for a minimum of 72 hours. Wait a minimum of 72 hours before returning furniture to the surface.
7. **IMPORTANT** – Chair mats are required under caster wheels/rolling chairs. This system is not intended for use under constant heavy rolling loads. Ecore cannot be held liable for failure to protect flooring surface.

*** Flash Time:** The waiting time required before installing flooring.

****Working Time:** The window of time for the adhesive to accept flooring.

ADHESIVE INSTALLATION OVER QT

E-Grip Evolve

Premium High Performance Adhesive for QT Sound Underlayment, Luxury Vinyl Tile and Plank

DESCRIPTION

E-Grip Evolve is a high performance, wet-set adhesive designed for use with Ecore's QT sound underlayment membranes, LVT and Plank.

Application Characteristics over Porous Substrates

	Flash Time	Working Time
Permanent bonding (Rubber)	0 minutes	Approximately 30 minutes

Application Characteristics over Nonporous Substrates

	Flash Time *	Working Time **
Permanent bonding (Rubber)	0 minutes	Approximately 30-45 minutes

Application Characteristics over Sound Mat

	Flash Time *	Working Time **
Permanent bonding (LVT/LVP) over 5mm sound mat using a 1/16" square notch trowel	90-120 minutes or until adhesive valley is clear and adhesive ridges are gummy to the touch	120-165 minutes, or approximately 30-45 minutes after flash time over sound mat
Permanent bonding (LVT/LVP) over 2mm sound mat using a 1/32"x1/16"x1/32" trowel	30-45 minutes or until adhesive valley is clear and adhesive ridges are gummy to the touch	45-75 minutes, or approximately 15-30 minutes after flash time over sound mat

* **Flash Time:** The waiting time required before installing flooring.

****Working Time:** The window of time for the adhesive to accept flooring.

Note: Flash and working times may vary based on temperature, humidity, substrate porosity, trowel size and jobsite conditions.

ADHESIVE INSTALLATION OVER STANDARD SUBSTRATES

E-Grip Evolve

Premium High Performance Adhesive for QT Sound Underlayment, Luxury Vinyl Tile and Plank

DESCRIPTION

E-Grip Evolve is suitable for installation of Luxury Vinyl Tile and Plank over other approved substrates. **For installation involving QT sound mats in conjunction with LVT/LVP, please refer to previous page's instructions.**

Application Characteristics over Porous Substrates

	Flash Time	Working Time
Permanent bonding (LVT/LVP) Use manufacturer's recommended trowel size	15-30 minutes or until adhesive valley is clear and adhesive ridges are wet to the touch	Approximately 15-30 minutes

Application Characteristics over Nonporous Substrates

	Flash Time *	Working Time **
Permanent bonding (LVT/LVP) Use manufacturer's recommended trowel size	30-45 minutes or until adhesive valley is clear and adhesive ridges are wet to the touch	Approximately 30-45 minutes



* **Flash Time:** The waiting time required before installing flooring.

****Working Time:** The window of time for the adhesive to accept flooring.

Note: Flash and working times may vary based on temperature, humidity, substrate porosity, trowel size and jobsite conditions.

ADHESIVE DATA

Limitations
Do not install over substrates containing asbestos
For interior installations only
Do not apply over existing adhesive residue
Use only when substrate temperature is between 65°F and 90°F (16°C and 32°C)
Follow flooring manufacturer's instructions for installation and substrate preparation

QT	Trowel Size		Coverage Rate Over Standard Substrates	Coverage Rate Over Sound Mats
2mm QT	 1/32" x 1/16" x 1/32" (1 x 1.5 x 1 mm)	Use to secure 2mm QT to substrate and LVT/LVP to 2mm QT	150 to 200 sq. ft./gal	150 sq. ft./gal
5mm QT	 1/16" x 1/16" x 1/16" (1.5 x 1.5 x 1.5 mm)	Use to secure 5mm QT to substrate and LVT/LVP to 5mm QT	100 to 125 sq. ft./gal	100 sq. ft./gal
Coverage rates shown here are for estimating purposes only. Actual jobsite coverage may vary according by application method, substrate, substrate conditions, trowel angle, and actual thickness applied				

PHYSICAL DATA	
Adhesive Type	Vinyl Acrylic Polymer
Antimicrobial	Yes
Color	Off-white
Consistency	Creamy
Density	8.3 lbs/gal (3.77 kg per 3.79 L)
VOC Content	.28 lbs/gal (34 g/l)
Shelf Life	2 years when stored at 73° F (23°C)
Flash point	>212°F (100°C)
pH	7 to 9
Maximum RH (ASTM F-2170)	80% RH diminishing
Freeze/Thaw	Protect from freezing Freeze/Thaw stable up to 5 cycles at 0°F (-18°C)

WARRANTY

Limited Lifetime Warranty

The QT line of products can be installed under most types of grouted, glued, and floating floors including ceramic tile, stone, marble, brick, pavers, hardwood, engineered wood, laminate, parquet, sheet vinyl, LVT and carpet. All floor covering assemblies shall have prior approval before installation.

The recommendations for applications and installation are based on our extensive experience and on current technological practice. Our liability and responsibility in the event of damages is limited to the extent defined in our General Terms and Conditions of Business and is not in any way increased by the above recommendations or by advice given by our sales representatives or applications engineering staff.

Ecore offers a limited lifetime warranty on the QT brand of Impact Sound Insulation products against defects in material and workmanship and they shall meet all published specifications and shall perform effectively. Ecore warrants that during the warranty period QT shall not harden, become brittle, chip, crack, tear, or exhibit any signs of excessive deterioration except for normal wear and tear. For means of identification, Lifetime means for as long as the job installation remains unchanged by the original owner.

All other warranties, including implied warranties for a particular purpose, wear due to ultraviolet degradation, and uses and installation that are contrary to QT specifications, recommendations or instructions are expressly excluded.

Approved LVT for use over select Ecore sound mats is intended for residential and light commercial use. For means of identification, Residential is defined as a single family detached dwelling and light commercial is defined as multi-family residential projects, such as condominiums, apartments, timeshares, and other such dwellings that are not subjected to industrial traffic or heavy rolling loads. It is the sole responsibility of the installer, general contractor, architect or specifier, as a condition of warranty coverage, to first determine suitability and compatibility of our system for the end user's intended use.

These warranties are in lieu of any other warranty expressed or implied. Ecore shall not be liable for any incidental or consequential damages which may result from a defect. Some states do not allow the exclusion or limitation of incidental or consequential damages, so the above limitation or exclusion may not apply to you. These warranties give you specific rights, and you may also have rights which may vary from state to state. To know what your legal rights are in your state, consult your local or state Consumer Affairs Office or your State Attorney General.



866-326-5712 – www.qtsoundcontrol.com

Manufactured in the U.S.A by:

ecore™

© 2020 All designs and colors are copyrighted by Ecore